

Ledex® Rotary Solenoids Size 5B Bobbin Coil

Performance Specifications

Stroke	Holding Torque ² (lb-in)	Starting Torque (lb-in) ¹ @ 20°C Maximum Duty Cycle				
		100%	50%	25%	10%	5%
25°	4.0	1.8	3.5	5.8	8.3	10.0
35°	*	0.9	2.1	4.1	6.9	8.3
45°	3.0	0.7	1.7	3.2	5.0	6.0
67½°	*	0.5	1.1	2.0	3.3	4.0
95°	2.0	0.2	0.4	0.9	1.6	1.9

All data is at 20°C coil temperature. Force (torque) outputs degrade with elevated temperatures.

- ¹ Gross starting torques are shown. For net available starting torque, subtract return spring torque of 0.25 lb.-in. ±20%.
- ² Holding torque is shown at the stabilized temperature of 105°C and continuous duty.
- * Consult factory.

ROTARY Solenoids

All catalog products manufactured after April 1, 2006 are RoHS Compliant

How to Order

- Using the Performance Chart to the left, select one of the five columns which provides the appropriate duty cycle for your application. Reading down this column locate the torque for the stroke you need. For net available starting torque, subtract return spring torque of 0.25 lb.-in. ±20% (if torque is insufficient go to next larger solenoid size).
- Use the chart below to select the model number corresponding to your desired design, stroke and direction of rotation (as viewed from armature end, opposite mounting studs).
- Using the Specification Chart to the right, select the same duty cycle column. Follow down the column into the VDC ratings. Select the voltage which most closely matches your supply voltage. Read across to the left to select the coil awg suffix.
- Replace the last two digits of the model number (XX) with the coil awg number to complete the part number.

Please see www.ledex.com (click on Stock Products tab) for our list of stock products available through our North American distributors.

- Armature cover
- Base end shaft
- Return spring

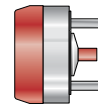

Stroke/ Direction*	Nom. Axial Stroke	
25° CW	0.042"	810-380-5XX
25° CCW	0.042"	810-385-5XX
35° CW	0.045"	810-381-5XX
35° CCW	0.045"	810-386-5XX
45° CW	0.045"	810-382-5XX
45° CCW	0.045"	810-387-5XX
67½° CW	0.050"	810-383-5XX
67½° CCW	0.050"	810-388-5XX
95° CW	0.055"	810-384-5XX
95° CCW	0.055"	810-389-5XX

* Direction of rotation (cw – clockwise or ccw – counterclockwise) is viewed from the armature end of the solenoid opposite the mounting studs.

Note: The XX in the part number suffix must be filled in with the awg of your choice.

Ledex® Rotary Solenoids Size 5B Bobbin Coil

Coil Specifications

Maximum Duty Cycle	100%	50%	25%	10%	5%
Maximum ON Time (sec) when pulsed continuously ¹	∞	100	36	10	3.5
Maximum ON Time (sec) for single pulse ²	∞	160	44	13	4.6
Watts (@ 20°C)	21	42	84	210	420
Ampere Turns (@ 20°C)	890	1250	1760	2800	3987

Coil Data

awg (0XX) ³	Resistance (@20°C)	# Turns ⁴	VDC (Nom)	VDC (Nom)	VDC (Nom)	VDC (Nom)	VDC (Nom)
23	2.01	294	6.1	8.5	12.0	19.1	27.0
24	3.15	364	7.7	10.8	15.2	24.0	35.0
25	4.88	448	9.7	13.6	19.2	31.0	43.0
26	7.72	564	12.2	17.1	24.0	38.0	55.0
27	10.90	648	15.0	21.0	30.0	47.0	67.0
28	18.20	836	19.4	27.0	38.0	61.0	87.0
29	30.40	1105	25.0	34.0	48.0	77.0	110.0
30	42.50	1248	30.0	43.0	60.0	95.0	136.0
31	69.00	1590	39.0	54.0	76.0	122.0	173.0
32	107.00	2006	48.0	67.0	94.0	149.0	213.0
33	169.00	2470	61.0	86.0	120.0	192.0	273.0

General Specifications

Dielectric Strength	23 awg, 1000 VRMS; 24-33 awg, 1200 VRMS
Recommended Minimum Heat Sink	Maximum watts dissipated by solenoid are based on an unrestricted flow of air at 20°C, with solenoid mounted on the equivalent of an aluminum plate measuring 7½" square by ⅛" thick.
Coil Resistance	±10% tolerance
Starting Torque	Gross torque values are shown. For net starting torque, subtract return spring torque
Return Spring Torque	0.25 pound-inches ±20%
Weight	10 oz (283.5 gm)
Dimensions	See page D33

- ¹ Continuously pulsed at stated watts and duty cycle.
- ² Single pulse at stated watts (with coil at ambient room temperature 20°C).
- ³ Other coil awg sizes available, consult factory.
- ⁴ Reference number of turns.

All specifications subject to change without notice.

- No shafts
- 3 tapped holes
- Return spring

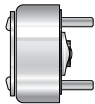

- Armature end shaft
- 3 tapped holes
- Return spring

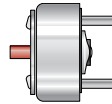

- Base end shaft
- 3 tapped holes
- Return spring

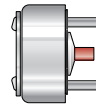

- Double shaft
- 3 tapped holes
- Return spring

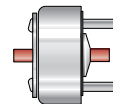

810-640-5XX
810-645-5XX

810-641-5XX
810-646-5XX

810-642-5XX
810-647-5XX

810-643-5XX
810-648-5XX

810-644-5XX
810-649-5XX

810-490-5XX
810-495-5XX

810-491-5XX
810-496-5XX

810-492-5XX
810-497-5XX

810-493-5XX
810-498-5XX

810-494-5XX
810-499-5XX

810-360-5XX
810-365-5XX

810-361-5XX
810-366-5XX

810-362-5XX
810-367-5XX

810-363-5XX
810-368-5XX

810-364-5XX
810-369-5XX

810-280-5XX
810-285-5XX

810-281-5XX
810-286-5XX

810-282-5XX
810-287-5XX

810-283-5XX
810-288-5XX

810-284-5XX
810-289-5XX

Ledex® Rotary Solenoids 5B Dimensions

Inches (mm)

Armature Cover Configuration — Base End Shaft

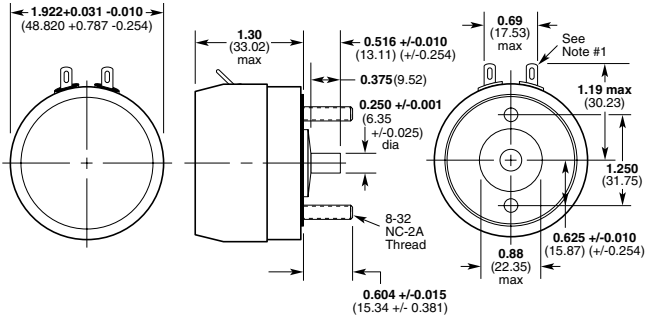

Notes:

- 1) All configurations have solder lug terminals, 0.170" (4.32) wide x 0.018" (0.457) thick.
- 2) For electrical specs and performance charts, see pages D20-D21.

All specifications subject to change without notice.

ROTARY Solenoids

No Shaft

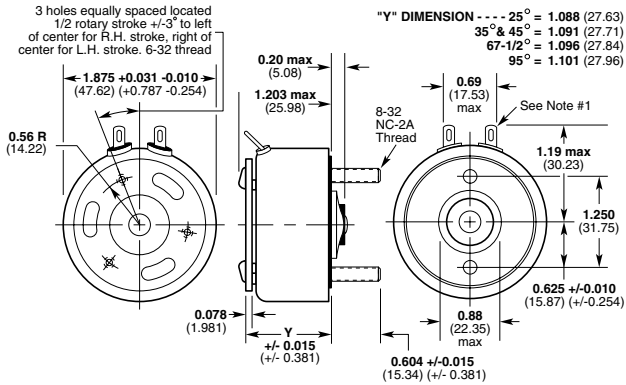

Base End Shaft

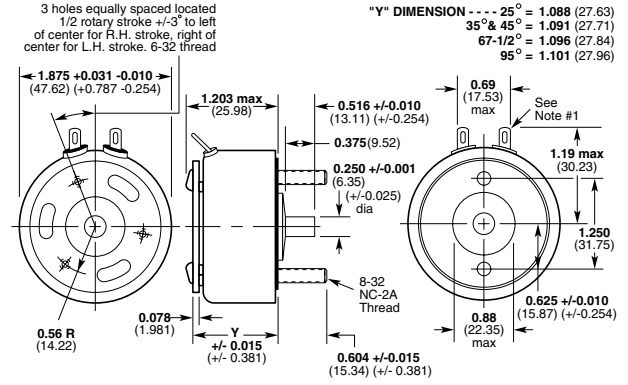

Armature End Shaft

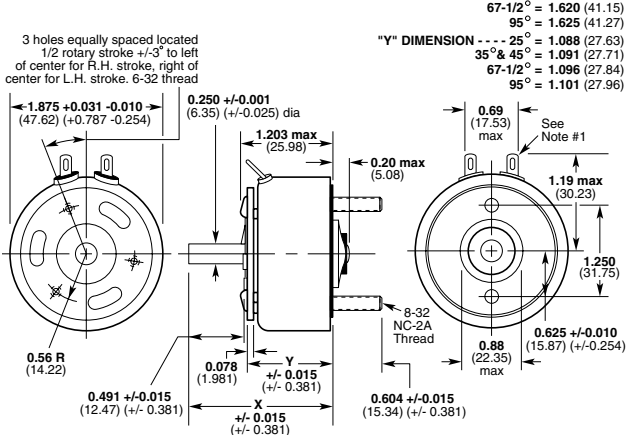

Double Shaft

