

UVTOP280

Absolute Maximum Ratings at $T_A = 25\text{ }^\circ\text{C}$

Parameter	Unit	Maximum Rated Value
Power Dissipation, DC	mW	180 (TO-39)
Forward Current, DC	mA	30
Pulse Forward Current (Duty Factor = 1%, Frequency = 1KHz)	mA	200
Reverse Voltage	V	6
Operating Temperature Range	$^\circ\text{C}$	- 30 to + 55
Storage Temperature	$^\circ\text{C}$	- 30 to +100

Electro-Optical Characteristics at $T_A = 25\text{ }^\circ\text{C}$, $I_F = 20\text{ mA}$

Peak Wavelength λ_p (nm)	PKG Type	Lens Type	Part Number	Optical Power P_{out} (μW)		Forward Voltage V_F (V)		Viewing Angle $2\theta_{1/2}$ ($^\circ$)	FWHM (nm)	
				Min	Typ.	Typ.	Max		Typ.	Max
285 Min: 280 nm Max: 290 nm	TO-18	FW	UVTOP280 TO18FW	300	500	5.8	7.0	120	12	15
		BL	UVTOP280 TO18BL	300	500	5.8	7.0	10	12	15
	TO-39	FW	UVTOP280 TO39FW	480	800	5.8	7.0	120	12	15
		HS	UVTOP280 TO39HS	360	600	5.8	7.0	7	12	15
		BL	UVTOP280 TO39BL	360	600	5.8	7.0	7	12	15
		TFW	UVTOP280 TO39TFW	180	300	5.8	7.0	120	12	15
		TFWR	UVTOP280 TO39TFWR	240	400	5.8	7.0	120	12	15

Notes:

Peak wavelength measurement tolerance is +/- 2 nm

Optical power output measurement tolerance is +/- 10%

Forward voltage measurement tolerance is +/- 2%



- This UV LED radiates intense UV light during operation. Do not expose any part of a human body to UV light. This can be harmful especially to the eyes and skin, even for a brief period due to the intense UV light.
- If viewing the UV light is necessary, please use UV filtered glasses to avoid damage by the UV light.
- If the UV LED in your product might be viewed directly, please affix a caution label to your production to that effect.

Typical Spectral Characteristics

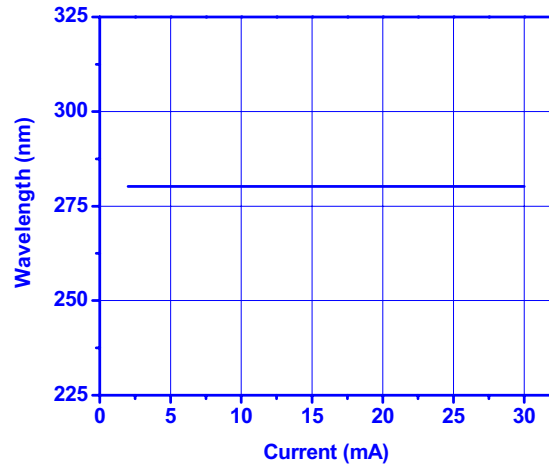
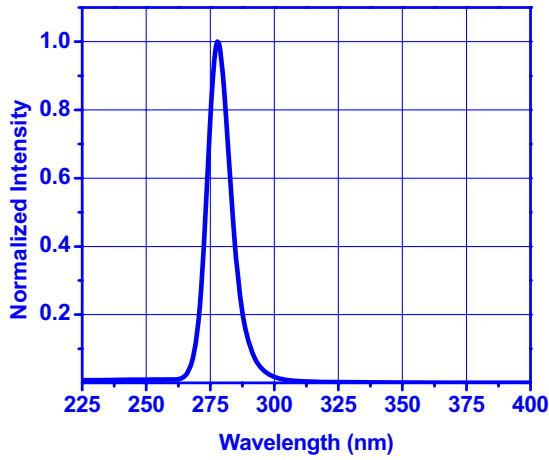

Typical LED Performance at $T_A = 25^\circ\text{C}$ (UVTOP280TO39BL)

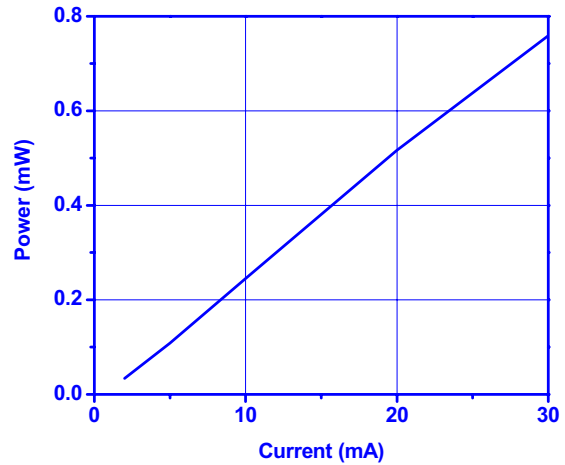
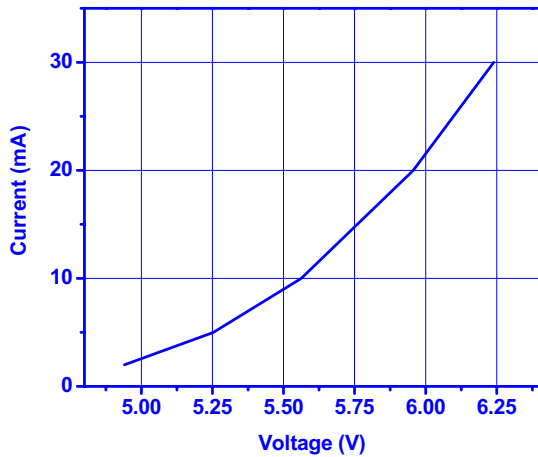

- This UV LED radiates intense UV light during operation. Do not expose any part of a human body to UV light. This can be harmful especially to the eyes and skin, even for a brief period due to the intense UV light.
- If viewing the UV light is necessary, please use UV filtered glasses to avoid damage by the UV light.
- If the UV LED in your product might be viewed directly, please affix a caution label to your production to that effect.

TO-39 with Tall Flat Window

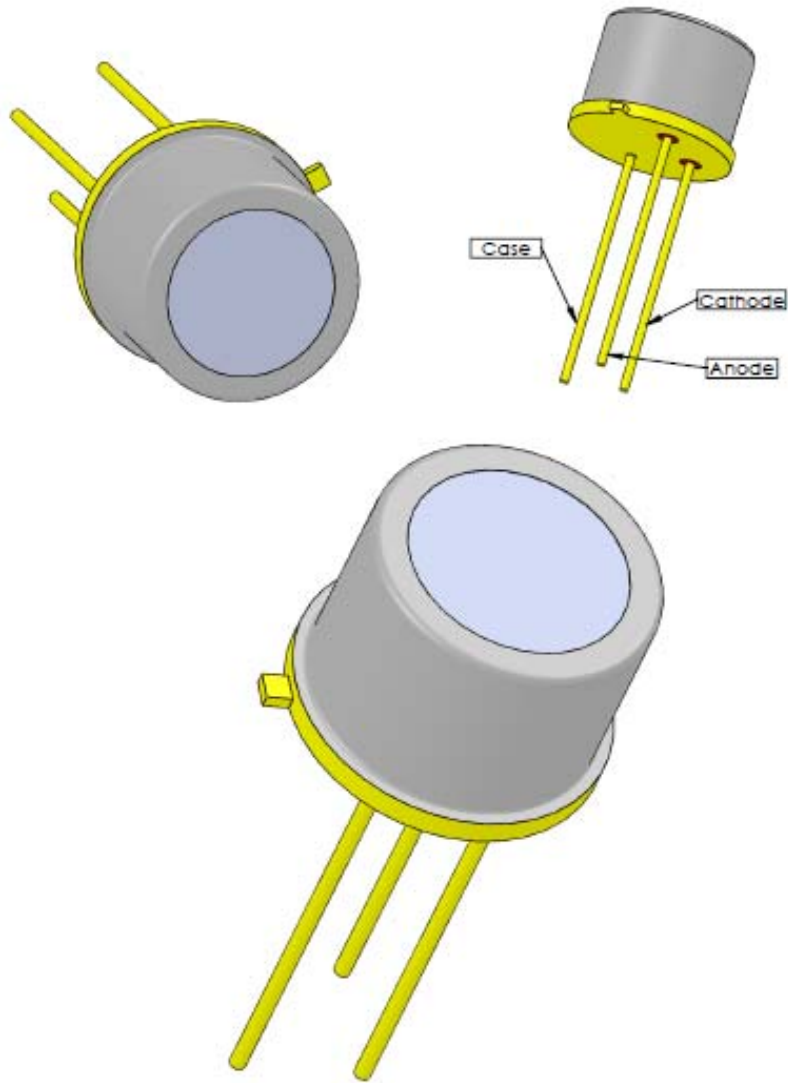
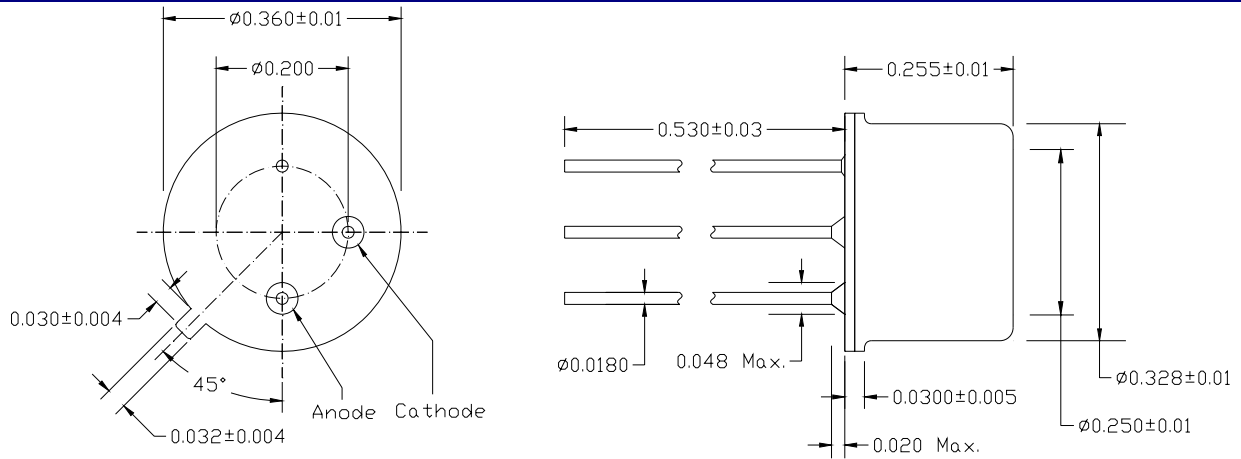

Notes: All dimensions are in inches. Dimensions without tolerances are nominal.



- This UV LED radiates intense UV light during operation. Do not expose any part of a human body to UV light. This can be harmful especially to the eyes and skin, even for a brief period due to the intense UV light.
- If viewing the UV light is necessary, please use UV filtered glasses to avoid damage by the UV light.
- If the UV LED in your product might be viewed directly, please affix a caution label to your production to that effect.

Typical Emission Pattern

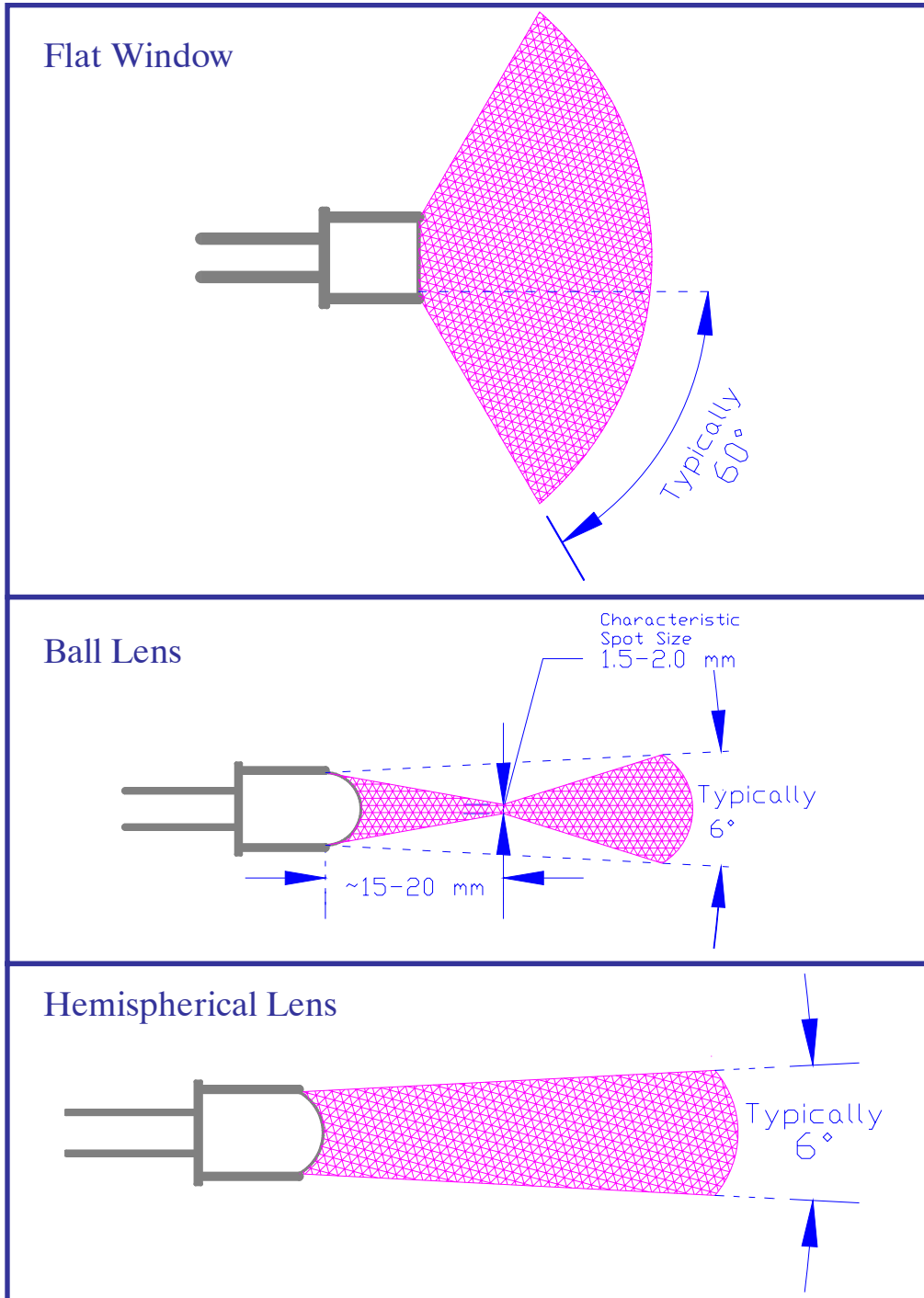

- This UV LED radiates intense UV light during operation. Do not expose any part of a human body to UV light. This can be harmful especially to the eyes and skin, even for a brief period due to the intense UV light.
- If viewing the UV light is necessary, please use UV filtered glasses to avoid damage by the UV light.
- If the UV LED in your product might be viewed directly, please affix a caution label to your production to that effect.

Typical Angular Diagrams

Flat Window

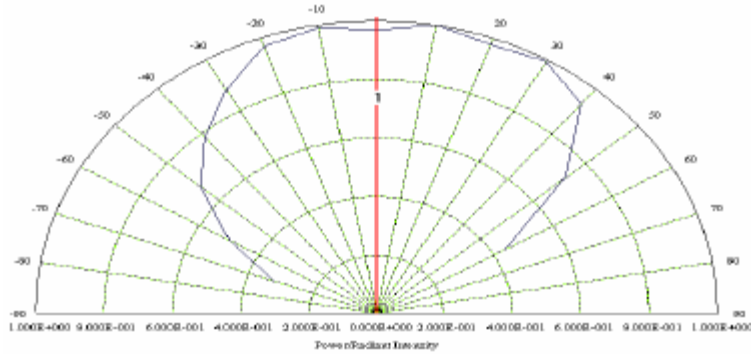

Ball Lens

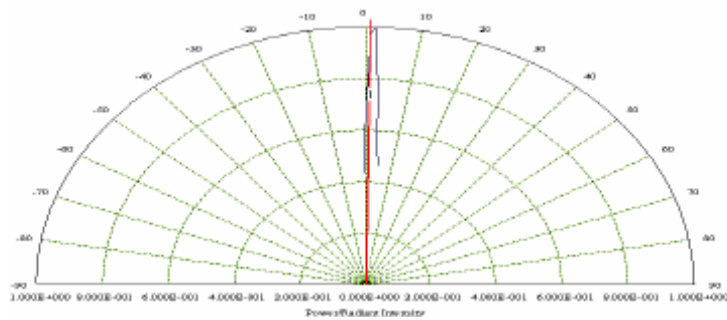

Hemispherical Lens

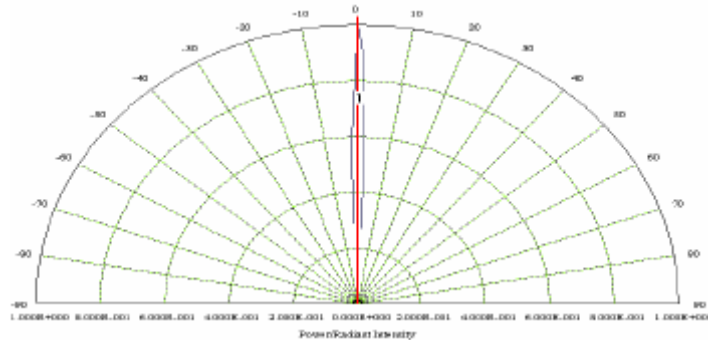

- This UV LED radiates intense UV light during operation. Do not expose any part of a human body to UV light. This can be harmful especially to the eyes and skin, even for a brief period due to the intense UV light.
- If viewing the UV light is necessary, please use UV filtered glasses to avoid damage by the UV light.
- If the UV LED in your product might be viewed directly, please affix a caution label to your production to that effect.

Recommended Soldering Conditions

Dip soldering (for TO-18, TO-39, TO-5 only):

Pre –heat time, Max.	30 seconds
Solder Bath temperature, Max.	190 °C
Dipping time, Max.	5 seconds
Dipping Positioning on leads	No closer than 3 mm from the base of the header

Soldering 1 (for TO-18, TO-39, TO-5):

Temperature of solder point, Max.	190 °C
Soldering time, Max.	5 seconds
Soldering position on leads	No closer than 3 mm from the base of the header

Soldering 2 (TO-3, TO-3-TEC, TO-5-TEC, TO-18-fiber):

Temperature of solder point, Max.	160 °C
Soldering time, Max.	5 seconds
Soldering position on leads	No closer than 3 mm from the base of the header
Soldering to header/cap/ferrule	Will destroy the device

Following conditions should be avoided during soldering: Overheating, Static Electricity, Mechanical Shock, Vibration, Ultrasonic Shock, Mechanical Damage and Contamination.

- Soldering must be done to the package leads only. Soldering to the LED header or cap will destroy the device.
- If clamping of LED is required, mechanical stress on the LED should be minimized.
- Soldering point must be no closer than 3 mm from the base of the header.
- Mechanical stress, shock and vibration must be avoided during soldering.
- It is not recommended to mount the LED directly on a PC board or a heat sink by soldering to the LED header or cap.
- Only non-corrosive flux must be used.
- Do not use dip soldering for TO-3 based, TO-18-fiber and TO-5-TEC packages.
- If it is necessary to cut the device leads, do so at room temperature using the ESD protected tool only. Do not apply any stress to the leads when heated.
- Do not apply current to the device until it cools down to room temperature after soldering.
- Failure to follow the recommendations may cause breakdown of the LED.



- This UV LED radiates intense UV light during operation. Do not expose any part of a human body to UV light. This can be harmful especially to the eyes and skin, even for a brief period due to the intense UV light.
- If viewing the UV light is necessary, please use UV filtered glasses to avoid damage by the UV light.
- If the UV LED in your product might be viewed directly, please affix a caution label to your production to that effect.