

FM CONNECTOR

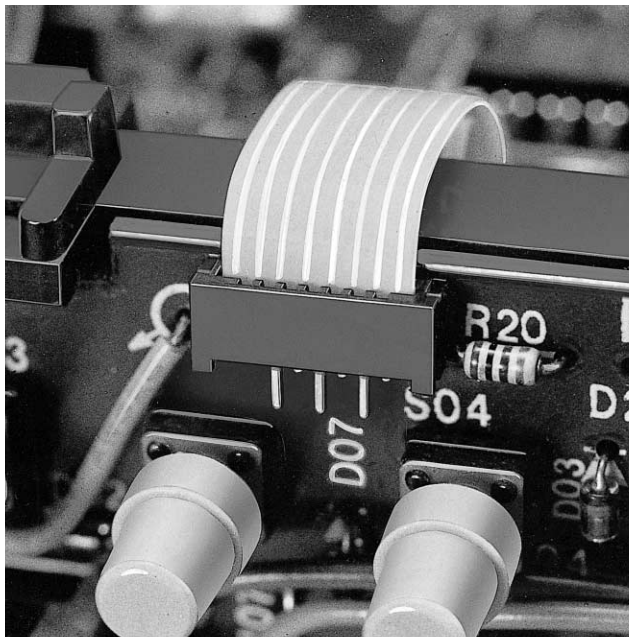

Connectors for FFC and FPC



The FM connector, a miniature connector with a thickness of only 3.0mm (.118"), was developed to connect flexible flat cables (FFC) or flexible printed circuits (FPC) with a lead pitch of 1.0mm (.039") to printed circuit boards. It is ideally suited for connections inside high-density equipment or between mechanical units. The contact is constructed to ensure a stable connection and high reliability even under vibration and impact. Connection is easy with a simple snap-in action.

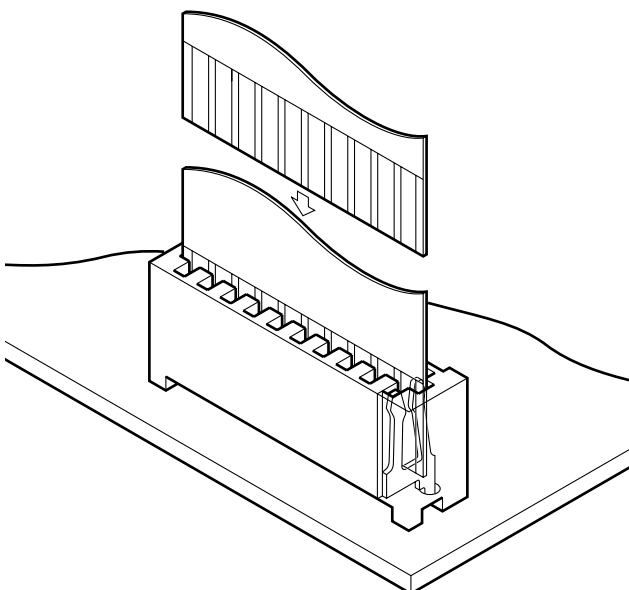

Features

• Compact

Having no complicated cam or slide mechanism, this connector is very small with a mounting height of only 4.4mm (.173") and a width of 3.0mm (.118").

• Double-sided contact

This connector has highly resilient phosphor bronze contacts, each of which has two independent mating spring members that ensure continuity even when subjected to severe vibration. Because each of the contacts simultaneously mates with both sides of the FFC or FPC, the engineer has greater freedom in designing his circuitry.

• Simple snap-in action

The FFC or FPC are securely connected by simply inserting their leads into the connector.

• Surface mount model (SMT)

This connector is also available in a surface mount configuration. Its housing is made of heat resistant resin so that it is not adversely affected during reflow soldering. Because of its tiny size and ability to be surface mounted, this connector meets the demand for high-density mounting of components inside electronic products.

Specifications

- Current rating: 0.5A AC, DC
- Voltage rating: 50V AC, DC
- Temperature range: -25°C to +85°C
(including temperature rise in applying electrical current)
- Contact resistance: Initial value/20m Ω max.
After environmental testing/30m Ω max.
- Insulation resistance: 800M Ω min.
- Withstanding voltage: 500V AC/minute
- Applicable FFC and FPC: Lead pitch /1.0mm(.039")
Lead width /0.7mm(.028")
Mating part thickness /
0.33^{+0.02}_{-0.03}mm(.013^{+0.0008}_{-.001})
- Applicable PC board thickness: 0.8 to 1.6mm(.031" to .063")

<Note>FFC/FPC to be actually used should be checked for applicability.

- * Contact JST if Lead-Free product is required.
- * Refer to "General Instruction and Notice when using Terminals and Connectors" at the end of this catalog.
- * Contact JST for details.

Standards

Ⓜ Recognized E60389

Ⓢ Certified LR20812

Connector

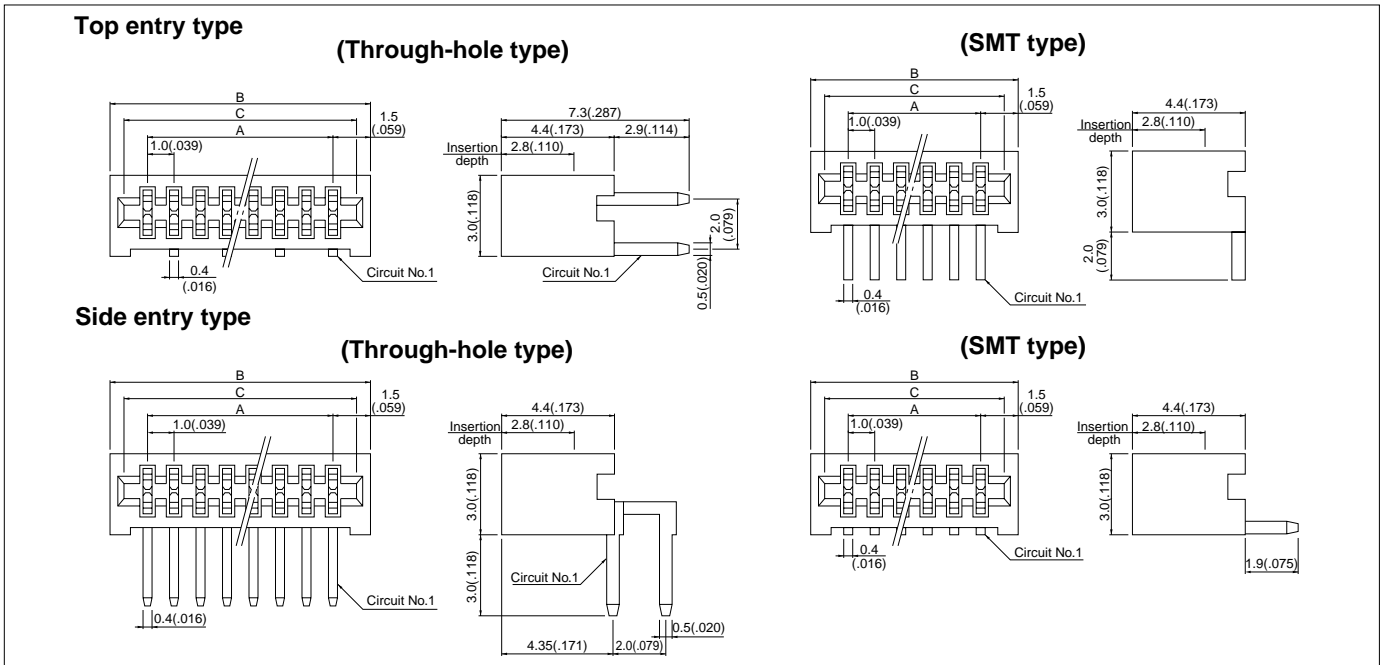

Through-hole type connector

Circuits	Model No. of Through-hole type		Dimensions mm(in.)			Q'ty / box
	Top entry type	Side entry type	A	B	C	
3	03FM-1.0BT	03FM-1.0ST	2.0(.079)	5.0(.197)	4.1(.161)	2,000
4	04FM-1.0BT	04FM-1.0ST	3.0(.118)	6.0(.236)	5.1(.201)	2,000
5	05FM-1.0BT	05FM-1.0ST	4.0(.157)	7.0(.276)	6.1(.240)	2,000
6	06FM-1.0BT	06FM-1.0ST	5.0(.197)	8.0(.315)	7.1(.280)	1,000
7	07FM-1.0BT	07FM-1.0ST	6.0(.236)	9.0(.354)	8.1(.319)	1,000
8	08FM-1.0BT	08FM-1.0ST	7.0(.276)	10.0(.394)	9.1(.358)	1,000
10	10FM-1.0BT	10FM-1.0ST	9.0(.354)	12.0(.472)	11.1(.437)	1,000
11	11FM-1.0BT	11FM-1.0ST	10.0(.394)	13.0(.512)	12.1(.476)	1,000
12	12FM-1.0BT	12FM-1.0ST	11.0(.433)	14.0(.551)	13.1(.516)	1,000

SMT type connector on embossed-tape

Circuits	Model No		Dimensions mm(in.)			Q'ty / reel	
	Top entry type	Side entry type	A	B	C	Top entry type	Side entry type
3	-	03FM-1.0SP-1.9-TF	2.0(.079)	5.0(.197)	4.1(.161)	-	2,500
4	04FM-1.0BP-TF	04FM-1.0SP-1.9-TF	3.0(.118)	6.0(.236)	5.1(.201)	1,000	2,500
5	05FM-1.0BP-TF	05FM-1.0SP-1.9-TF	4.0(.157)	7.0(.276)	6.1(.240)	1,000	2,500
6	06FM-1.0BP-TF	06FM-1.0SP-1.9-TF	5.0(.197)	8.0(.315)	7.1(.280)	1,000	2,500
7	07FM-1.0BP-TF	07FM-1.0SP-1.9-TF	6.0(.236)	9.0(.354)	8.1(.319)	1,000	2,500
8	08FM-1.0BP-TF	08FM-1.0SP-1.9-TF	7.0(.276)	10.0(.394)	9.1(.358)	1,000	2,500
10	-	10FM-1.0SP-1.9-TF	9.0(.354)	12.0(.472)	11.1(.437)	-	2,000
12	-	12FM-1.0SP-1.9-TF	11.0(.433)	14.0(.551)	13.1(.516)	-	2,000

Material and Finish

(Through-hole type) Contact: Phosphor bronze, copper-undercoated, tin/lead-plated
Housing: PBT, UL94V-0
(SMT type) Contact: Phosphor bronze, copper-undercoated, tin/lead-plated
Housing: PPS, UL94V-0

FM CONNECTOR

Taping specifications

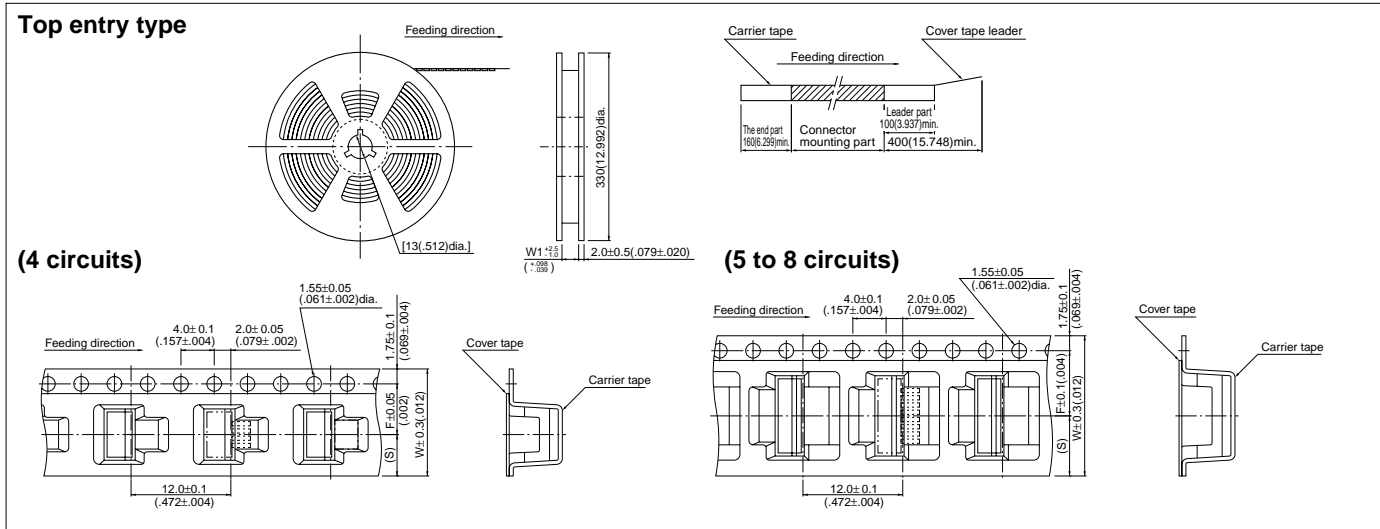

Circuits	Taping dimensions mm(in.)			Reel dimensions mm(in.)		Q'ty /reel
	F	S	W	W1	W2	
4	5.5(.217)	4.75(.187)	12.0(.472)	13.5(.531)		1,000
5 to 8	7.5(.295)	6.75(.266)	16.0(.630)	17.5(.689)		1,000

Note:

- Specifications conform to JIS C 0806. The tape width, connector recess dimensions, etc. are determined by the number of circuits and external shape of the connector to be loaded.
- Specifications are subject to change without prior notice.

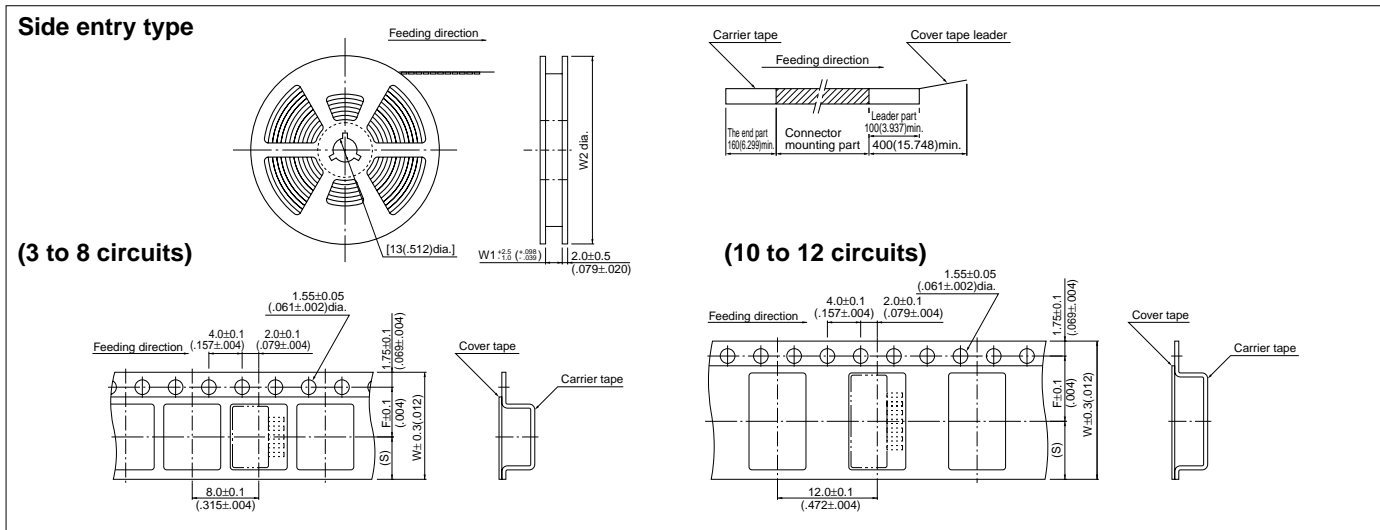

Circuits	Taping dimensions mm(in.)			Reel dimensions mm(in.)		Q'ty /reel
	F	S	W	W1	W2	
3 to 4	5.5(.217)	4.75(.187)	12.0(.472)	13.5(.531)	330(12.992)	2,500
5 to 8	7.5(.295)	6.75(.266)	16.0(.630)	17.5(.689)	330(12.992)	2,500
10 to 12	11.5(.453)	10.75(.423)	24.0(.945)	25.5(1.004)	380(14.961)	2,000

Note:

- Specifications conform to JIS C 0806. The tape width, connector recess dimensions, etc. are determined by the number of circuits and external shape of the connector to be loaded.
- Specifications are subject to change without prior notice.

Lead section dimensions of FFC and FPC

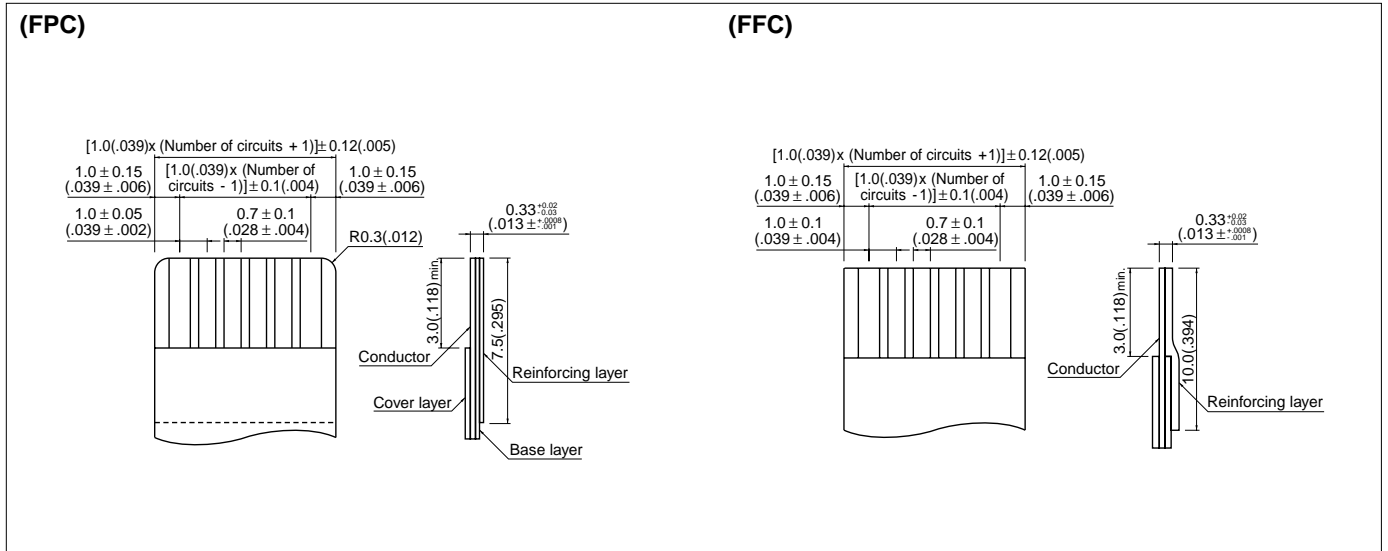

PC board layout and Assembly layout

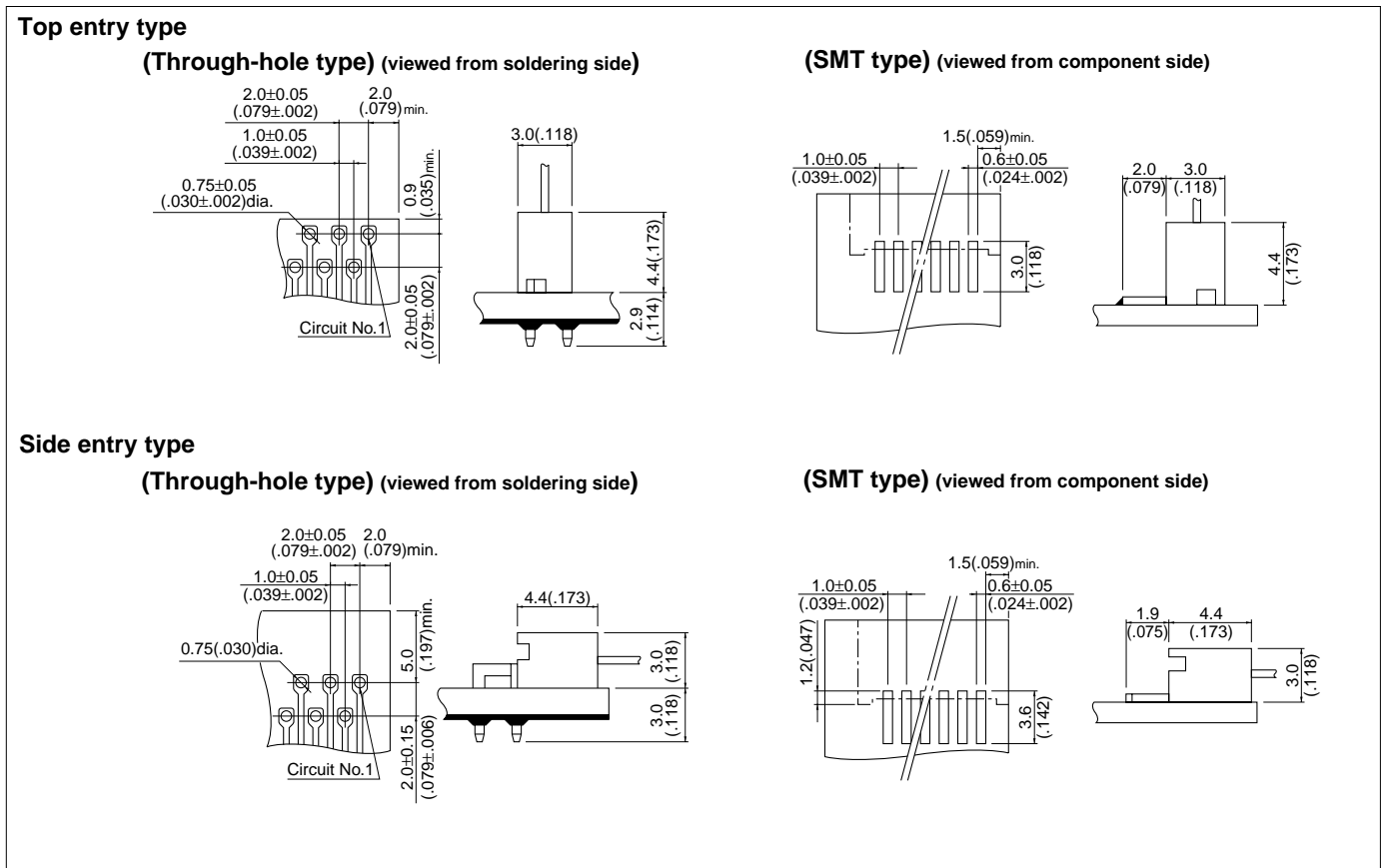

Note:

1. Tolerances are non-cumulative: $\pm 0.05\text{mm}(\pm .002")$ for all centers.
2. Hole dimensions differ according to the kind of PC board and piercing method. The dimensions above should serve as a guideline.
3. It is recommended that surface mount connectors be secured using thermosetting resin or something similar. Contact JST for details.