

DA CONNECTOR

Board-in Insulation displacement connectors

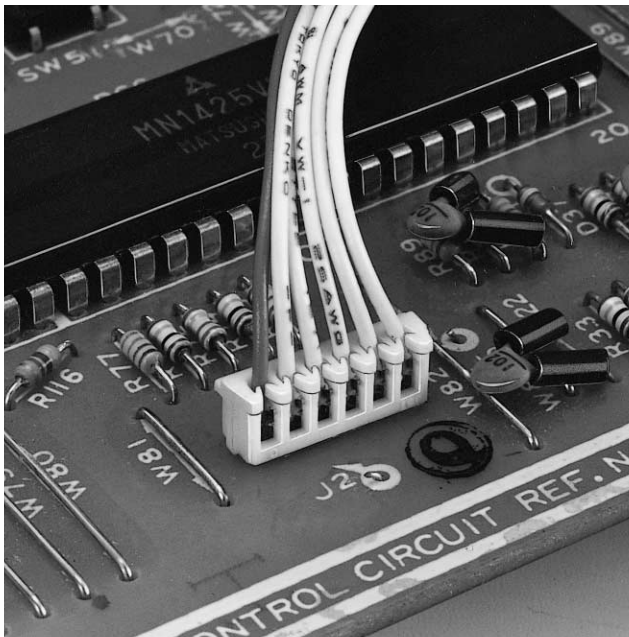

Measuring 2.0mm (.079") in pitch, 5.0mm (.197") in mounting height, and 4.0mm (.157") in thickness, this board-in connector is useful in miniaturizing the connections of small electronic products, such as VCRs, cameras, stereo systems, and car radios. This connector can be used by itself or in combination with the DR connector.

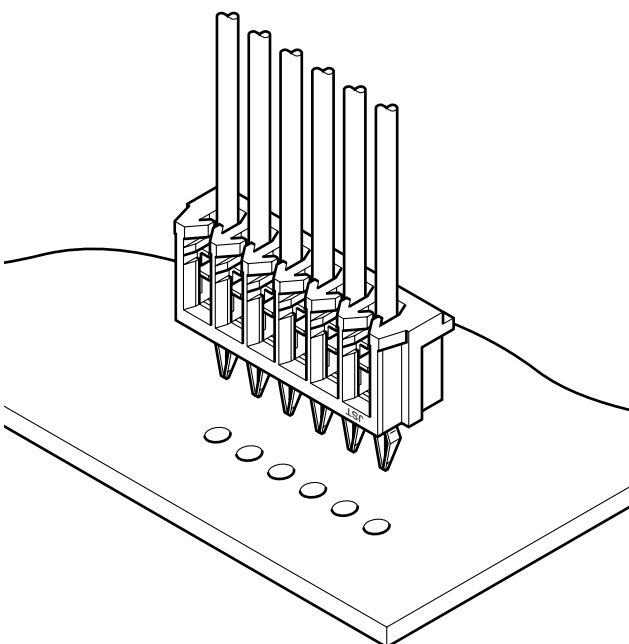

Features

• Compact and low profile

The connector is very small, with a mounting height of 5.0mm (.197") and a thickness of 4.0mm (.157").

• Twin U-slot insulation displacement section

The insulation displacement section connected to each wire consists of two tin-plated slots (twin U-slots), which ensures reliable connection.

• Easy mounting onto printed circuit boards

The board insertion section of the contact is resilient to ensure easy and secure insertion onto printed circuit boards.

• Strain relief

The housing has a strain-relief that grips the wire insulation to ensure that the gas tight connection will not be degraded by excessive vibration or tension.

• Interchangeability

The DA connector is interchangeable with the 2.0mm (.079") pitch crimp style board-in connector (SAN connector) in terms of insertion hole size and pitch.

Specifications

- Current rating: 1.0A AC, DC (AWG #26)
- Voltage rating: 100V AC, DC
- Temperature range: -25°C to +85°C
(including temperature rise in applying electrical current)
- Insulation resistance: 1,000M Ω min.
- Withstanding voltage: 800V AC/minute
- Applicable wire: UL1571, 1061(Contact JST regarding other UL wires.)
AWG #28, #26
Conductor/7 strands, tin-coated
Insulation O.D./ 0.9 to 1.0mm(0.35" to .039")
- Applicable PC board thickness: 1.2, 1.6mm(.047", .063")
- * Contact JST if Lead-Free product is required.
- * Refer to "General Instruction and Notice when using Terminals and Connectors" at the end of this catalog.
- * Contact JST for details.

Standards

Recognized E60389

Certified LR20812

DA CONNECTOR

Connector

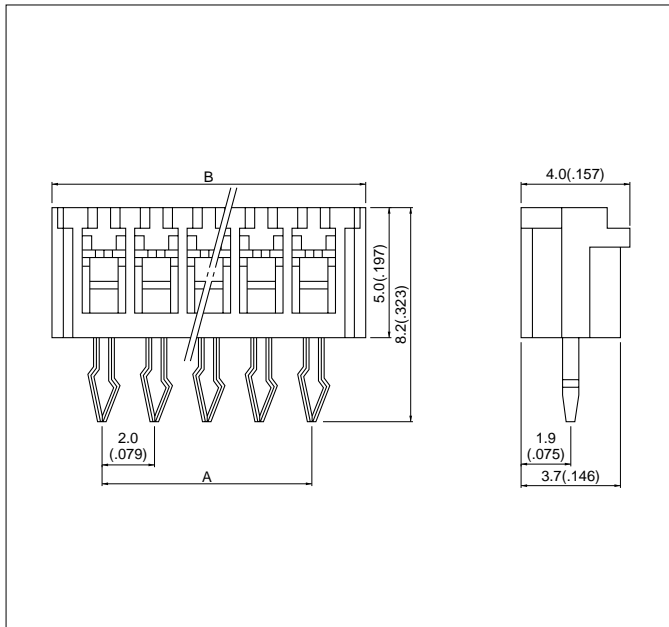

Circuits	Model No.		Dimensions mm(in.)		Q'ty / box
	AWG #28 (green)	AWG #26 (natural/white)	A	B	
2	02DA-8M	02DA-6S	2.0(.079)	5.9(.232)	2,000
3	03DA-8M	03DA-6S	4.0(.157)	7.9(.311)	2,000
4	04DA-8M	04DA-6S	6.0(.236)	9.9(.390)	1,000
5	05DA-8M	05DA-6S	8.0(.315)	11.9(.469)	1,000
6	06DA-8M	06DA-6S	10.0(.394)	13.9(.547)	1,000
7	07DA-8M	07DA-6S	12.0(.472)	15.9(.626)	1,000
8	08DA-8M	08DA-6S	14.0(.551)	17.9(.705)	1,000
9	09DA-8M	09DA-6S	16.0(.630)	19.9(.783)	500
10	10DA-8M	10DA-6S	18.0(.709)	21.9(.862)	500
11	11DA-8M	11DA-6S	20.0(.787)	23.9(.941)	500
12	12DA-8M	12DA-6S	22.0(.866)	25.9(1.020)	500
13	13DA-8M	13DA-6S	24.0(.945)	27.9(1.098)	500
14	14DA-8M	14DA-6S	26.0(1.024)	29.9(1.177)	500
15	15DA-8M	15DA-6S	28.0(1.102)	31.9(1.256)	250

Material and Finish

Contact: Phosphor bronze, copper-undercoated, tin/lead-plated
Housing: Nylon 66, UL94V-0

PC board layout (viewed from soldering side) and Assembly layout

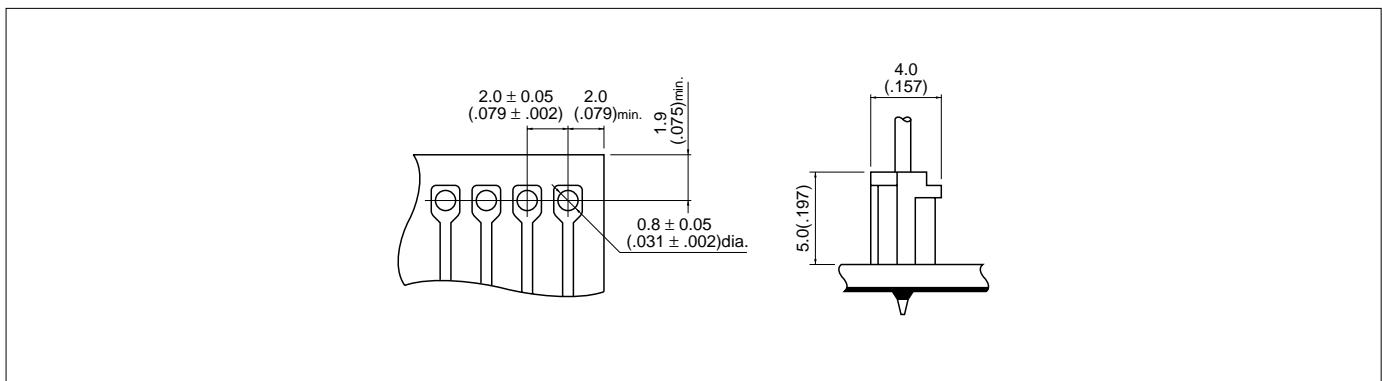

Note:

1. Tolerances are non-cumulative: $\pm 0.05\text{mm}(\pm .002")$ for all centers.
2. Hole dimensions differ according to the kind of PC board and piercing method. The dimensions above should serve as a guideline. Contact JST for details.

* Pulling or otherwise putting a strain on the harness attached to the connector before the solder has completely cooled can dislodge the connector or cause its misalignment.

* Do not reuse any connectors that were previously soldered and then removed from a PC board.