

## GLOBAL SALES OFFICES

### America

**Hypertronics Corporation**  
 16 Brent Drive  
 Hudson, MA 0174, USA  
 t: +1 (0) 978 5680451  
 f: +1 (0) 978 5680680  
 e: info@hypertronics.com

### Asia

**Hypertac China**  
 Unit F1, 7th Floor,  
 East Ocean Center  
 Phase II, No.618 Yan'An Road East  
 Shanghai, China 200001  
 t: +86 21 3318 4650  
 f: +86 21 5385 5377  
 e: infochina@hypertronics.com

**Hypertac India**  
 c/o John Crane Sealing Systems  
 India Pvt. Ltd.  
 No.11, 1<sup>st</sup> Phase Peenya  
 Industrial Area,  
 Bangalore-560058, India  
 t: +91 80 2839 2200  
 f: +91 80 2839 8205/06  
 e: info@hypertac.fr

**Hypertac Japan**  
 Toward-senju No.1, 801, Senju 3-6,  
 Adachi, Tokyo, Japan, 120-0034  
 t: +81-3-3870-8205  
 f: +81-3-3870-8264  
 e: info.japan@hypertac.it

### Russia

**Hypertronics Corporation**  
 c/o John Crane Sealing Systems  
 B.Afanasyevsky per., 41A  
 Moscow 119019 Russia  
 t / f: +78452 462149  
 e: inforussia@hypertronics.com

### Europe

**Hypertac Limited**  
 36 Waterloo Road  
 London NW2 7UH, UK  
 t: +44 (0) 20 8450 8033  
 f: +44 (0) 20 8208 4114  
 e: info@hypertac.co.uk

**Hypertac SpA**  
 Via P.D. Da Bissone 7A,  
 16153 Genova-Sestri P., Italy  
 t: +39 0 10 60361  
 f: +39 0 10 6036280  
 e: info@hypertac.it

**Hypertac GmbH**  
 Ulrichsberger Straße 17,  
 94469 Deggendorf, Germany  
 t: +49 (0) 991 250120  
 f: +49 (0) 991 2501244  
 e: info@hypertac.de

**Hypertac S.A.**  
 31 rue Isidore Maille,  
 76410 St. Aubin Lès Elbeuf, France  
 t: +33 (0) 2 32969176  
 f: +33 (0) 2 32969170  
 e: info@hypertac.fr



FOR FURTHER INFORMATION VISIT [www.hypertronics.com](http://www.hypertronics.com)

Distributor

Copyright© 2010 Hypertronics Corporation - All rights reserved. Hypertac is a registered trademark of Smiths and/or its subsidiaries and affiliates. HYPERTRONICS and the H logo are trademarks of Hypertronics Corporation. All other names and marks are property of their respective owners. HYP-039-0110



**D SERIES**  
 SUPPLEMENT TO HYPERTRONICS  
 2010 FULL LINE CATALOG

**smiths**  
 bringing technology to life



### Circular Plastic Connectors

- 3, 4, 5, 7, 9, 12 and 25 position models
- 1 to 8 Amps per contact
- Mixed signal and power or coax available
- Each connector half accepts pins or sockets
- High temp ULTEM plastic body
- Quick disconnect push button release
- Alignment and polarization provided by housing
- Crimp, solder cup, and pc contacts

### Connector Dimensions

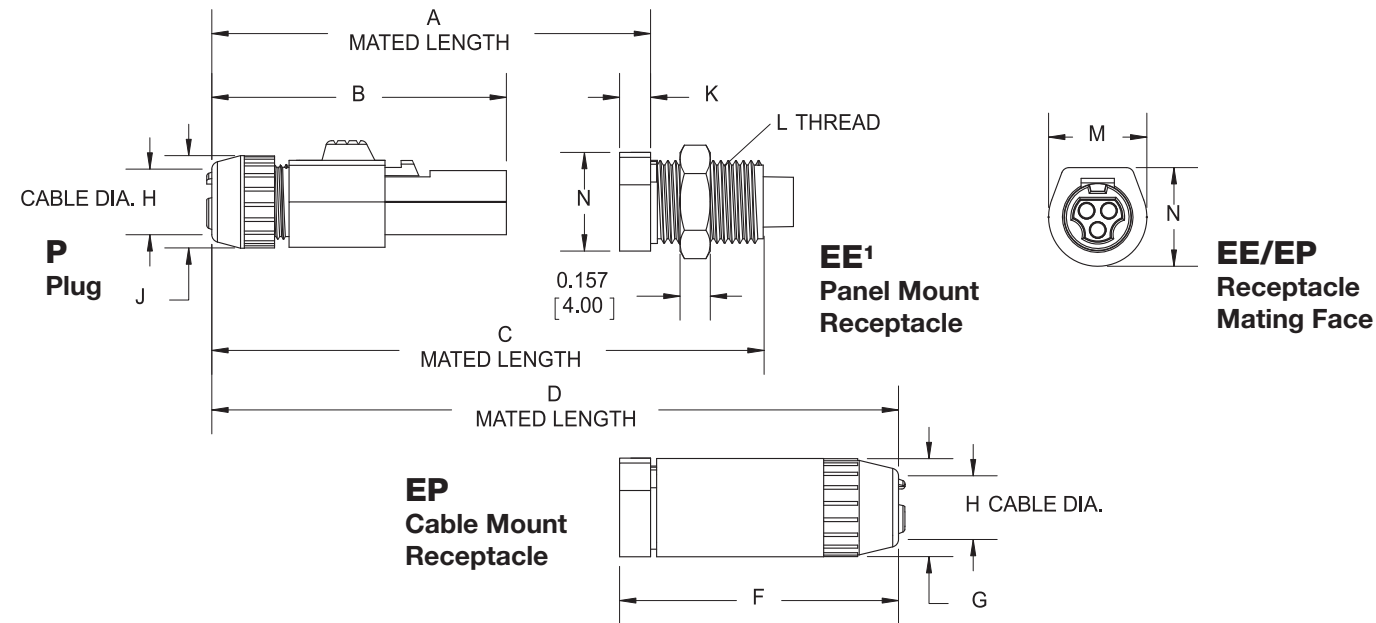

### Mounting Dimensions

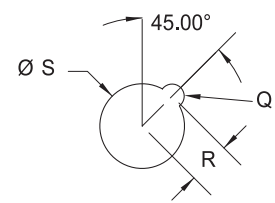

### Hole Punches

Part Number	Series	Maximum Recommended Panel Thickness in Steel	Maximum Recommended Panel Thickness in Alum.
TBD	D00	0.048 [1.25]	0.075 [1.90]
T1903	D01	0.048 [1.25]	0.075 [1.90]
T1904	D02	0.062 [1.60]	0.094 [2.40]

**NOTE:**  
1) Recommended tightening torque for panel mount receptacle (0.452-0.678 N•M) for both D01 and D02.

Dimensions are in inches [mm]

Dimension	D00 Housing	D01 Housing	D02 Housing
<b>A</b>	0.788 [20.00]	1.142 [29.00]	1.358 [34.50]
<b>B</b>	1.096 [27.83]	1.614 [41.00]	1.950 [49.50]
<b>C</b>	1.181 [30.00]	1.732 [44.00]	2.087 [53.00]
<b>D</b>	N/A	2.400 [61.00]	2.953 [75.00]
<b>F</b>	N/A	1.500 [38.00]	1.772 [45.00]
<b>G Dia.</b>	N/A	0.512 [13.00]	0.709 [18.00]
<b>H Cable Dia.</b>	0.089 [2.50] Min. 0.158 [4.00] Max.	0.118 [3.00] Min. 0.216 [5.50] Max.	0.197 [5.00] Min. 0.315 [8.00] Max.
<b>J Dia.</b>	0.352 [8.94]	0.472 [12.00]	0.709 [18.00]
<b>K</b>	0.114 [2.88]	0.161 [4.10]	0.278 [7.00]
<b>L</b>	M8 X 1.00	M11 X 1.00 Thd.	M15 X 1.00 Thd.
<b>M</b>	0.323 [8.20]	0.512 [13.00]	0.669 [17.00]
<b>N</b>	0.320 [8.12]	0.512 [13.00]	0.689 [17.50]
<b>Q Dia.</b>	0.092 [2.34]	0.126 [3.20]	0.100 [2.54]
<b>R</b>	0.161 [4.10]	0.220 [5.60]	0.295 [7.50]
<b>S Dia.</b>	0.323 [8.20]	0.441 [11.20]	0.598 [15.20]

### Panel Mount Receptacle (EE) D01 Shown

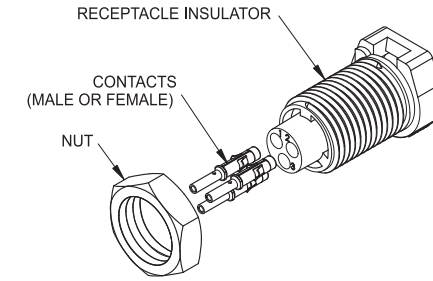

### Cable Mount Receptacle (EP) D01 Shown

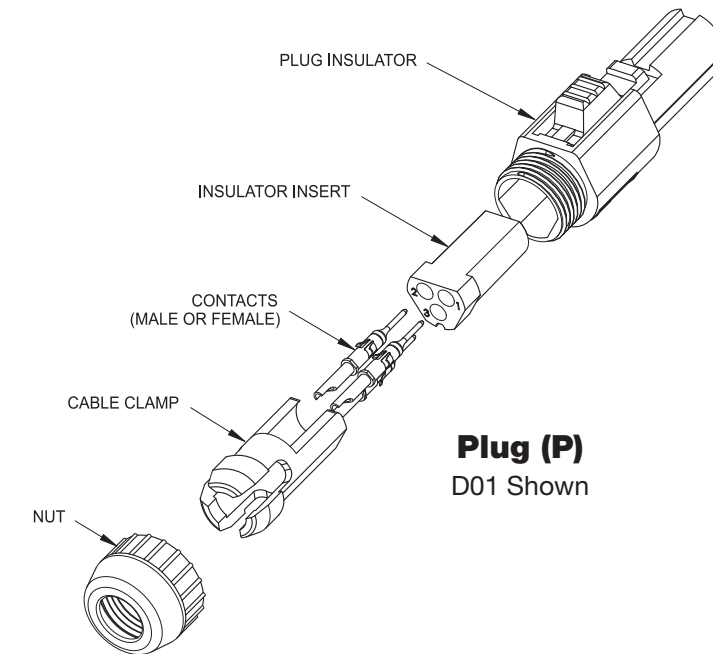
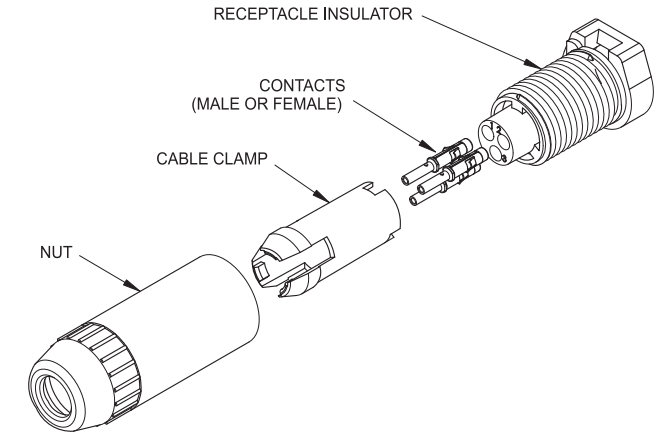

Dimensions are in inches [mm]

**D Series**



<b>D00 General Specifications</b>	
	<b>5 Pin</b>
Contact Diameter	0.012 [0.30]
Current Rating (Amps)	1
Contact Resistance (milliohms)	< 6.7
Extraction Force Per Contact (oz.)	0.35 to 1.6
Contact Life Cycles	up to 100,000
Breakdown Voltage Between Contacts	> 1000V
Dielectric Withstanding Voltage	>750V
<b>Contact</b>	
Socket Material	Beryllium copper wires and brass body (socket)
Pin Material	Brass; gold over nickel (pin)
Plating Material	Gold over nickel
Insulation Resistance	> 10 <sup>3</sup> megohms at 500 VDC
Temperature Rating	-40° C to 125° C

<b>D01 General Specifications</b>			
	<b>3 Pin</b>	<b>4 Pin</b>	<b>9 Pin</b>
Contact Diameter	0.024 [0.60]	0.024 [0.60]	0.016 [0.40]
Current Rating (Amps)	4	4	1
Contact Resistance (milliohms)	< 5	< 5	< 8
Extraction Force Per Contact (oz.)	0.50 to 2.00	0.50 to 2.00	0.60 to 1.60
Contact Life Cycles	100,000	100,000	100,000
Breakdown Voltage Between Contacts	> 2250V	> 2250V	> 1000V
Dielectric Withstanding Voltage	1650V	1650V	750V
<b>Contact</b>			
Socket Material	Beryllium copper wires and brass body (socket)		
Pin Material	Brass (pin)		
Plating Material	Gold over nickel		
Insulation Resistance	> 10 <sup>3</sup> megohms at 500 VDC		
Temperature Rating	-40° C to 125° C		

<b>Accessories</b>	<b>3 Pin</b>	<b>4 Pin</b>	<b>9 Pin</b>
Crimp Tool	AFM8 or (M22520/2-01)	AFM8 or (M22520/2-01)	AFM8 or (M22520/2-01)
Positioner	K547	K547	T1914
Removal Tool	S/DEM1.0060	S/DEM1.0060	—
Insertion Tool	T1866	T1866	T1916

Dimensions are in inches [mm]

**D Series**



<b>D02 General Specifications</b>					
	<b>3 Pin</b>	<b>7 Pin</b>	<b>9 Pin</b>	<b>12 Pin</b>	<b>25 Pin</b>
Contact Diameter	0.059 [1.50]	0.024 [0.60]	0.024 [0.60]	0.018 [0.50]	0.016 [0.40]
Current Rating (Amps)	8	4	4	2.5	1
Contact Resistance (milliohms)	< 2	< 5	< 5	< 8	< 8
Extraction Force Per Contact (oz.)	1.80 to 5.40	0.50 to 2.00	0.50 to 2.00	0.30 to 1.60	0.30 to 1.60
Contact Life Cycles	100,000	100,000	100,000	100,000	100,000
Breakdown Voltage Between Contacts	> 2250	> 2000	> 1560	> 1000	> 1000
Dielectric Withstanding Voltage	1650	1500	1150	750	750
<b>Contact</b>					
Socket Material	Beryllium copper wires and brass body (socket)				
Pin Material	Brass (pin)				
Plating Material	Gold over nickel				
Insulation Resistance	> 10 <sup>3</sup> megohms at 500 VDC				
Temperature Rating	-40° C to 125°				

<b>Accessories</b>	<b>3 Pin</b>	<b>7 and 9 Pin</b>	<b>12 Pin</b>	<b>25 Pin</b>
Crimp Tool	AF8	AFM8 or M22520/2-01	AFM8 or M22520/2-01	AFM8 or M22520/2-01
Positioner	TP688	K623	T870	T1914
Removal Tool	S/DEM5.0150	S/DEM1.0060	—	—
Insertion Tool	T1888	T1866	T1271	T1916

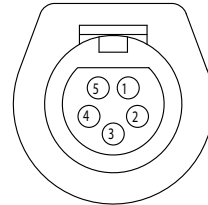
<b>D00 5 Pin</b>	<b>Housing Options</b>	<b>Example Part Numbers</b>
 <p>Receptacle seen from mating side</p>	Receptacle Panel Mount Plug	D00EEB503FRUTAH D00PB503MRUTH
	<b>Contact Options</b>	See part number configurator on page 2/10 for complete ordering information.
	Crimp Socket – 26-28 AWG Crimp Pin – 26-28 AWG	
	<b>Tools</b>	
	Crimp Tool Crimp Positioner Insertion Tool	AFM8 or M22520/2-01 T1914 T1916

Dimensions are in inches [mm]

**D Series**



<p><b>D01</b> <b>3 Pin</b></p> <p>Receptacle seen from mating side</p>	Housing Options	Example Part Numbers
	Receptacle Panel Mount Receptacle Cable Plug	D01EEB306FRUTAH D01EPB306FRUTAH D01PB306MRUT
	Contact Options	See part number configurator on page 2/10 for complete ordering information.
	Crimp Socket – 22-26 AWG Crimp Socket – 18-20 AWG Solder Cup Socket – up to 22 AWG Crimp Pin – 22-26 AWG Crimp Pin – 18-20 AWG Solder Cup Pin – up to 22 AWG	
Tools	Crimp Tool Crimp Positioner Removal Tool Insertion Tool	AFM8 or M22520/2-01 K547 S/DEM1.0060 T1866

<p><b>D01</b> <b>4 Pin</b></p> <p>Receptacle seen from mating side</p>	Housing Options	Example Part Numbers
	Receptacle Panel Mount Receptacle Cable Plug	D01EEB406FRUTAH D01EPB406FRUTAH D01PB406MRUT
	Contact Options	See part number configurator on page 2/10 for complete ordering information.
	Crimp Socket – 22-26 AWG Crimp Socket – 18-20 AWG Solder Cup Socket – up to 22 AWG Crimp Pin – 22-26 AWG Crimp Pin – 18-20 AWG Solder Cup Pin – up to 22 AWG	
Tools	Crimp Tool Crimp Positioner Removal Tool Insertion Tool	AFM8 or M22520/2-01 K547 S/DEM1.0060 T1866

<p><b>D01</b> <b>9 Pin</b></p> <p>Receptacle seen from mating side</p>	Housing Options	Example Part Numbers
	Receptacle Panel Mount Receptacle Cable Plug	D01EEB904FRUTAH D01EPB904FRUTAH D01PB904MRUT
	Contact Options	See part number configurator on page 2/10 for complete ordering information.
	Crimp Socket – 26-28 AWG Solder Cup Socket – up to 26 AWG Crimp Pin – 26-28 AWG Solder Cup Pin – up to 26 AWG	
Tools	Crimp Tool Crimp Positioner Insertion Tool	AFM8 or M22520/2-01 T1914 T1916

Dimensions are in inches [mm]

**D Series**



<p><b>D02</b> <b>3 Pin</b></p> <p>Receptacle seen from mating side</p>	Housing Options	Example Part Numbers
	Receptacle Panel Mount Receptacle Cable Plug	D02EEB315FRUTAH D02EPB315FRUTAH D02PB315MRUT
	Contact Options	See part number configurator on page 2/10 for complete ordering information.
	Crimp Socket – 18 and 20 AWG Solder Cup Socket – up to 16 AWG Crimp Pin – 18 and 20 AWG Solder Cup Pin – up to 16 AWG	
Tools	Crimp Tool Crimp Positioner Removal Tool Insertion Tool	AF8 TP688 S/DEM5.0150 T1888

<p><b>D02</b> <b>7 Pin</b></p> <p>Receptacle seen from mating side</p>	Housing Options	Example Part Numbers
	Receptacle Panel Mount Receptacle Cable Plug	D02EEB706FRUTAH D02EPB706FRUTAH D02PB706MRUT
	Contact Options	See part number configurator on page 2/10 for complete ordering information.
	Crimp Socket – 22-26 AWG Solder Cup Socket – up to 22 AWG Crimp Pin – 22-26 AWG Solder Cup Pin – up to 22 AWG	
Tools	Crimp Tool Crimp Positioner Removal Tool Insertion Tool	AFM8 or M22520/2-01 K623 S/DEM1.0060 T1866

<p><b>D02</b> <b>9 Pin</b></p> <p>Receptacle seen from mating side</p>	Housing Options	Example Part Numbers
	Receptacle Panel Mount Receptacle Cable Plug	D02EEB906FRUTAH D02EPB906FRUTAH D02PB906MRUT
	Contact Options	See part number configurator on page 2/10 for complete ordering information.
	Crimp Socket – 22-26 AWG Solder Cup Socket – up to 22 AWG Crimp Pin – 22-26 AWG Solder Cup Pin – up to 22 AWG	
Tools	Crimp Tool Crimp Positioner Removal Tool Insertion Tool	AFM8 or M22520/2-01 K623 S/DEM1.0060 T1866

Dimensions are in inches [mm]

**D Series**



<p><b>D02</b> <b>12 Pin</b></p> <p>Receptacle seen from mating side</p>	<p><b>Housing Options</b></p> <p>Receptacle Panel Mount Receptacle Cable Plug</p>	<p><b>Example Part Numbers</b></p> <p>D02EEB125FRUTAH D02EPB125FRUTAH D02PB125MRUT</p>
	<p><b>Contact Options</b></p> <p>Crimp Socket – 22-26 AWG Solder Cup Socket – up to 22 AWG Crimp Pin – 22-26 AWG Solder Cup Pin – up to 22 AWG</p>	<p>See part number configurator on page 2/10 for complete ordering information.</p>
	<p><b>Tools</b></p> <p>Crimp Tool Crimp Positioner Insertion Tool</p>	<p>AFM8 or M22520/2-01* T870 T1271</p>

<p><b>D02</b> <b>25 Pin</b></p> <p>Receptacle seen from mating side</p>	<p><b>Housing Options</b></p> <p>Receptacle Panel Mount Receptacle Cable Plug</p>	<p><b>Example Part Numbers</b></p> <p>D02EEB2504FRUTAH D02EPB2504FRUTAH D02PB2504MRUT</p>
	<p><b>Contact Options</b></p> <p>Crimp Socket – 26-28 AWG Solder Cup Socket – up to 26 AWG Crimp Pin – 26-28 AWG Solder Cup Pin – up to 26 AWG</p>	<p>See part number configurator on page 2/10 for complete ordering information.</p>
	<p><b>Tools</b></p> <p>Crimp Tool Crimp Positioner Insertion Tool</p>	<p>AFM8 or M22520/2-01 T1914 T1916</p>

Dimensions are in inches [mm]

**D Series**



**Combination Connectors Power and Signal**

• Two 8 Amp and seven 2.5 Amp Signal Contacts • Crimp Contacts

<p><b>D02</b> <b>Power and Signal</b></p> <p>Receptacle seen from mating side</p>	<p><b>Housing Options</b></p> <p>Receptacle Panel Mount Plug</p>	<p><b>Example Part Numbers*</b></p> <p>D02EEB215/705FRUTAH D02PB215/705MRUT</p>	
	<p><b>Contact Options</b></p> <p>Power Socket – 16-20 AWG Power Pin – 16-20 AWG Signal Socket – 22-26 AWG Signal Pin – 22-26 AWG</p>	<p>See part number configurator on page 2/10 for complete ordering information.</p>	
	<p><b>Tools</b></p> <p>Crimp Tool Crimp Positioner (Pin) Crimp Positioner (Socket) Removal Tool Insertion Tool</p>	<p><b>Power</b></p> <p>AF8 T1164 TP688 T1124 —</p>	<p><b>Signal</b></p> <p>AFM8 T870 T870 — T1215</p>

General Specifications		
Contacts	Power	Signal
Number of Contacts	2	7
Diameter	0.059 [1.50]	0.018 [0.50]
Current Rating (Amps)	8	2.50
Contact Resistance	< 2.0 milliohms	< 8.0 milliohms
Extraction Force	1.8 to 5.4 oz.	0.3 to 1.6 oz.
<b>Contact Material</b>	Brass	
Pins	Beryllium copper wires and brass body	
Sockets	Beryllium copper wires and brass body	
<b>Insulator Material</b>	Polycarbonate	
Receptacle	Polycarbonate	
Plug	Polycarbonate	
<b>Flammability</b>	UL94V0	
<b>Temperature Rating</b>	-40° C to 85° C	
<b>Insulation Resistance</b>	> 10 Mohm at 500 VDC	

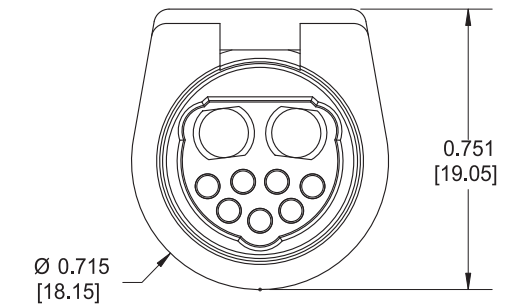

**NOTE:**  
\*B = Black Polycarbonate Available in Power and Signal.

Dimensions are in inches [mm]

**D Series**

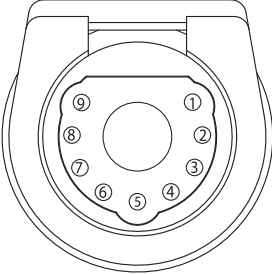

**Combination Connectors Coax or Power and Signal**

<p><b>D02</b> <b>Coax or Power and Signal</b></p>  <p>Receptacle seen from mating side</p>	<p><b>Housing Options</b></p> <p>Receptacle Panel Mount Receptacle Cable Plug</p>		<p><b>Example Part Numbers<sup>1</sup></b></p> <p>D02EEB905FR1C1FRUTHA D02EPB905FR1C1FRUTHA D02PB905MR1C1MRUT</p>																									
	<p><b>Contact Options</b></p> <p>Coax Crimp Socket – RRG 316, RG316DB Coax Solder Cup Socket – RG405, T-Flex 405 Coax Crimp Pin – RG316, RG316DB Coax Solder Cup Pin – RG405, T-Flex 405 Power Crimp Socket – 12 AWG Power Crimp Pin – 12 AWG Signal Crimp Socket – 22-26 AWG Signal Solder Cup Socket – 22-26 AWG Signal Crimp Pin – 22-26 AWG Signal Solder Cup Pin – 22-26 AWG</p>		<p>See part number configurator on page 2/10 for complete ordering information.</p>																									
	<p><b>Tools</b></p> <table border="1"> <thead> <tr> <th></th> <th>Coax</th> <th>Power</th> <th>Signal</th> </tr> </thead> <tbody> <tr> <td>Crimp Tool</td> <td>HX3 (Outer) AFM8 (Inner)</td> <td>M309</td> <td>AFM8</td> </tr> <tr> <td>Crimp Die Set</td> <td>T1958 (Outer) or T2019 (Outer for RG316DB)</td> <td>–</td> <td>–</td> </tr> <tr> <td>Crimp Positioner</td> <td>T1957 (Inner)</td> <td>T1981</td> <td>T870</td> </tr> <tr> <td>Removal Tool</td> <td>T1982</td> <td>T1982</td> <td>–</td> </tr> <tr> <td>Insertion Tool</td> <td>–</td> <td>–</td> <td>T1215</td> </tr> </tbody> </table>					Coax	Power	Signal	Crimp Tool	HX3 (Outer) AFM8 (Inner)	M309	AFM8	Crimp Die Set	T1958 (Outer) or T2019 (Outer for RG316DB)	–	–	Crimp Positioner	T1957 (Inner)	T1981	T870	Removal Tool	T1982	T1982	–	Insertion Tool	–	–	T1215
		Coax	Power	Signal																								
Crimp Tool	HX3 (Outer) AFM8 (Inner)	M309	AFM8																									
Crimp Die Set	T1958 (Outer) or T2019 (Outer for RG316DB)	–	–																									
Crimp Positioner	T1957 (Inner)	T1981	T870																									
Removal Tool	T1982	T1982	–																									
Insertion Tool	–	–	T1215																									

**NOTES:**  
1) H = Black Polyetherimide (High Temperature).  
2) Available in Coax or Power and Signal.

Dimensions are in inches [mm]

**D Series**



**Ordering Information**

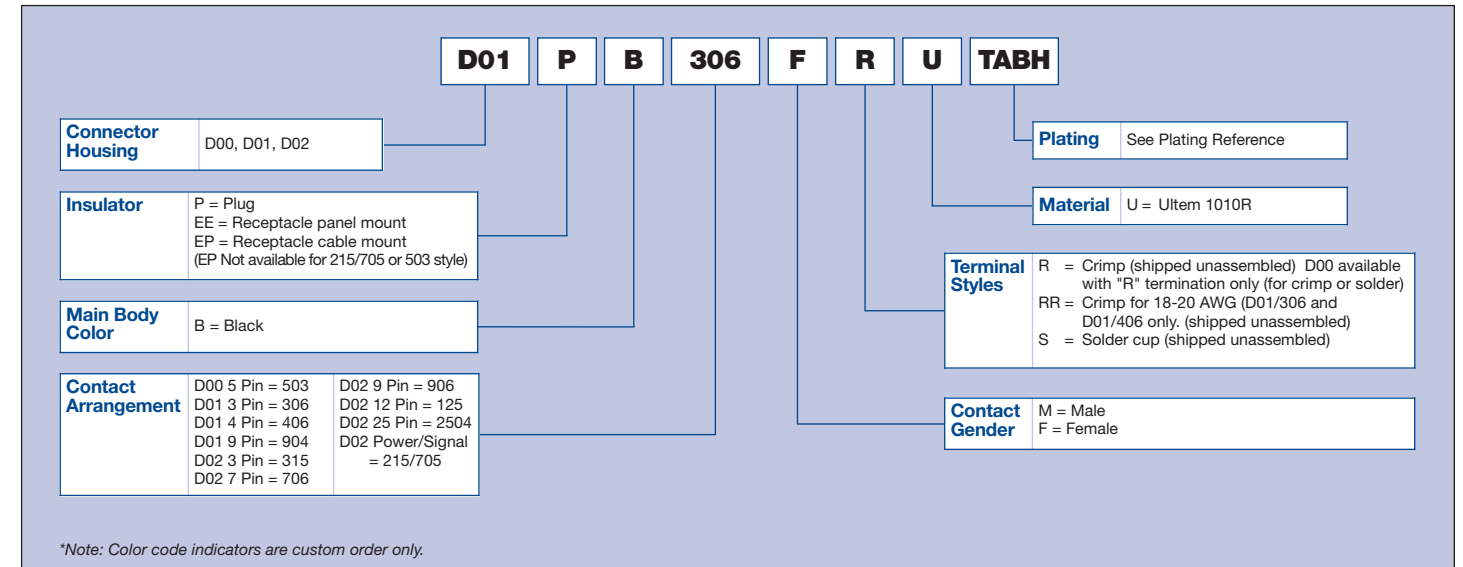

D00 panel mount receptacle with 6" pigtail leads pretermination = D00EEB-001

\*\* Mounting options are available, see <http://www.hypertronics.com/en/Products/circular-connectors/D-Series.aspx> or call (978) 568-0451 for more information.

**D02 Coax or Power and Signal Ordering Information**

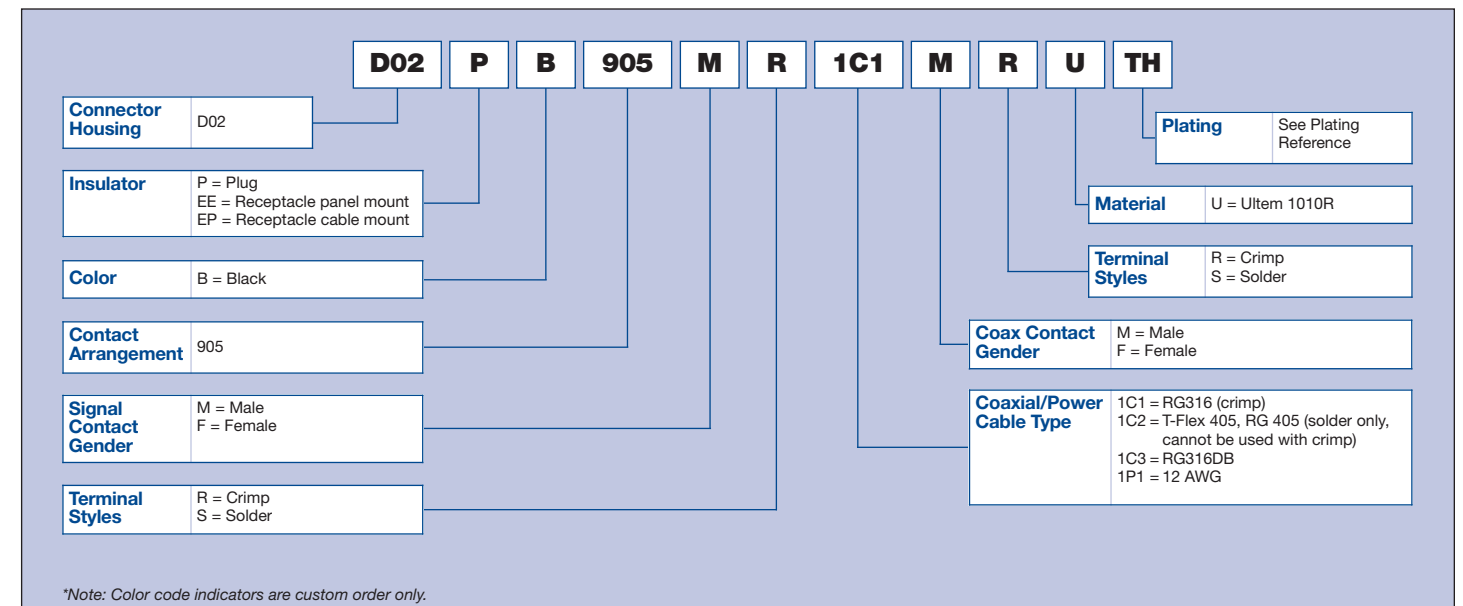

Plating Reference	
Male Pins:	T = 10µin gold (min) over nickel (NA 0n D00) TH = 50µin gold (min) over nickel
Female Sockets:	TAH = 50µin gold (min) over nickel on mating surface, gold flash over nickel on termination TABH = 50µin gold (min) over nickel on mating surface, tin lead over nickel on termination (D & B only)

Dimensions are in inches [mm]